

WINDOW INSTALLATION INSTRUCTIONS

Utility Slider Window Installation Instructions

Replacement/New Construction application
with the use of a nailing flange

Note: window openings should always be non load-bearing

REQUIRED TOOLS

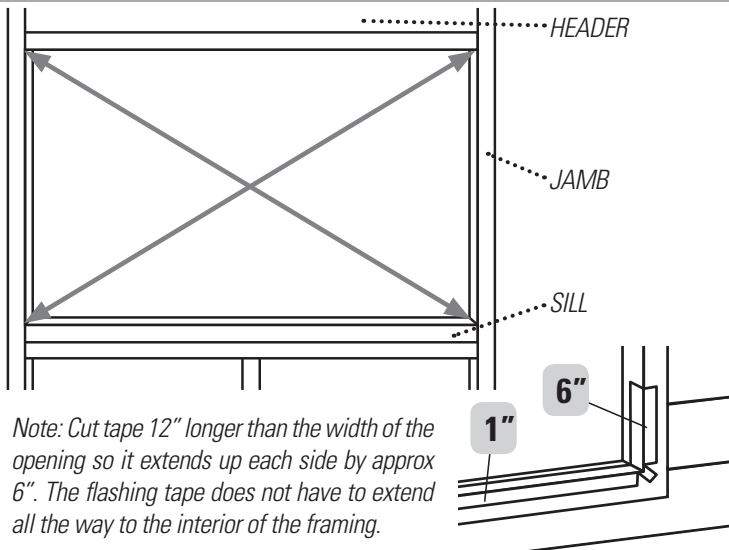
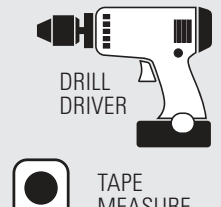
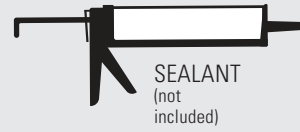

Note: Cut tape 12" longer than the width of the opening so it extends up each side by approx 6". The flashing tape does not have to extend all the way to the interior of the framing.

STEP 1. Check to be sure that the rough wall opening is square (diagonals measure the same). Cut a piece of flashing tape 12" longer than the opening width. Apply tape at the bottom of the opening so that it overhangs 1" to the exterior and 6" up each side of the opening, as shown.

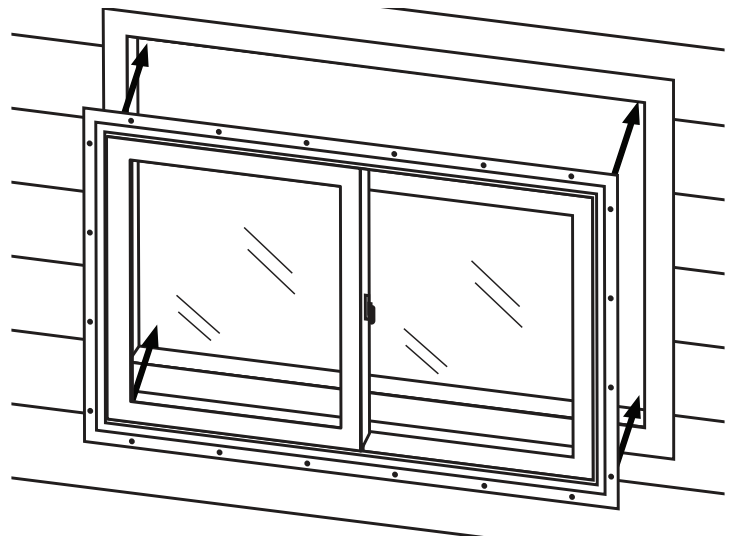

STEP 2. Place the window into the center of the opening, making sure that the window is level and centered within the rough opening. Apply sealant to the exterior of the buck frame then place the window into the center of the opening. Make sure that the window remains centered within the rough opening.

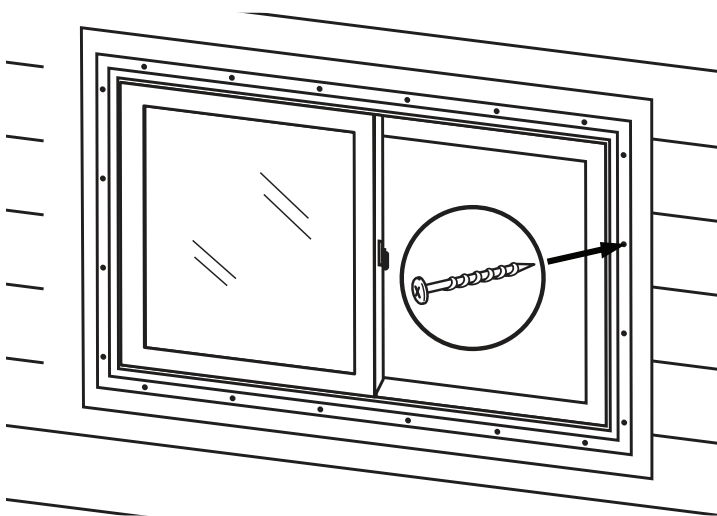

STEP 3. Once the unit is square in the opening, secure the window by using #8 x 2" galvanized or stainless steel pan head screws placed through the installation flange.

Caution, expanding foam sealants may make the window too tight in the opening and can negatively impact the operation of the window.

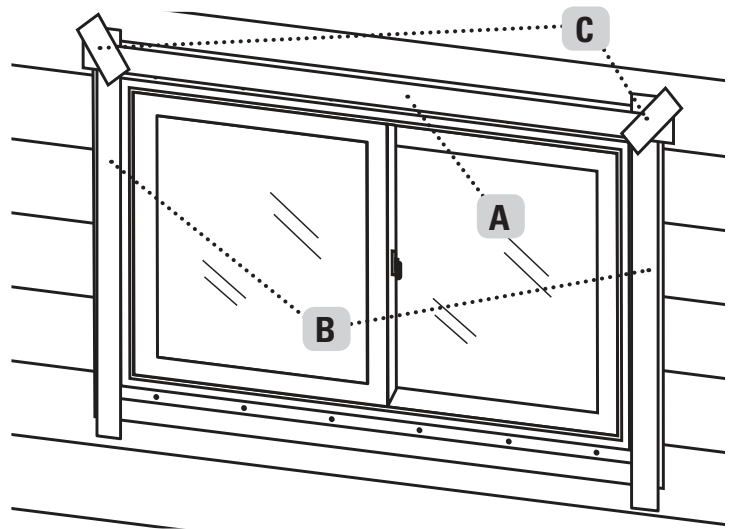

STEP 4. Apply flashing tape to top first, then along the sides and lastly to the upper corners. (A) Cut one piece of flashing tape long enough to go across the top of the window extending at least 1" past the side flashing tape on both sides. (B) Cut two pieces of tape 4" longer than the frame height of the window. (C) Apply tape to the top two corners of the window extending at least 1" past the corner tape seams.

DO NOT SEAL ACROSS THE BOTTOM INSTALLATION FLANGE.